



EH-MB18B



SRRC

**• Bluetooth Radio**

- Fully embedded Bluetooth® v4.0(Smart ready)
- Bluetooth® v3.0 specification compliant
- TX power +8dbm,-90dbm RX sensitivity
- 128-bit encryption security
- Range up to 15m
- Internal chip antenna or U.FL port
- Multipoint capability(7 transmit data devices connected at the same time)

• Support Profiles

- SPP (Master and slave), iAP (ipod accessory protocol)
- BLE(GATT Profile)
- HFP ,A2DP,AVRCP,HID(Salve)

• User Interface

- Send AT command over UART
- Firmware upgrade over USB
- With SPP service active: 560kbps transmission speed (UART)
- PCM interface (I2S,SPDIF)
- I2C interface(Master),SPI

• Audio Codec

- Optional support for 64Mb of external SPI flash
- 16Mb internal flash memory (64-bit wide, 45ns)
- 80MHz RISC MCU and 80MIPS Kalimba DSP
- Support for CSR's latest CVC technology for narrow-band and wideband voice connections including wind noise reduction
- Support Apt-X ,AAC, Apt-XLL,SBC codec

• General I/O

- 13 general purpose I/Os
- 2 analogue I/O
- Support for up to 3 capacitive touch sensor inputs
- Three fully configurable LED drivers
- **FCC/RED/KC/SRRC and Bluetooth® qualified**
- **Single voltage supply: 2.7-3.6V**
- **Small form factor: 30.4 x 15.26 x 2.4mm**
- **Operating temperature range: -40 °C to 85 °C**

Mar 1, 2017

VERSION HISTORY

Version	Comment
V1.0	Current consumption added
V1.1	Certification information updated.
V1.2	Update packing information
V1.3	Update contact list
V2.0	Update product code
V2.1	Addition Version History

Confidential and Proprietary – Ehong Technology Co.,Ltd

NO PUBLIC DISCLOSURE PERMITTED: Please report postings of this document on public servers or websites to: DCC@ehonglink.com

Restricted Distribution: Not to be distributed to anyone who is not an employee of either Ehong Technology Co.,Ltd or its affiliated companies without the express approval of Ehong Configuration Management.

Not to be used, copied, reproduced, or modified in whole or in part, nor its contents revealed in any manner to others without the express written permission of Ehong Technology Co.,Ltd.

This Bluetooth trademark is owned by the Bluetooth SIG Inc., USA and is licensed to Ehong Technologies. All other trademarks listed herein are owned by their respective owners.

© 2016 Ehong Technology Co.,Ltd. All rights reserved.

1. Contents

1. Description	5
2. Application	5
3. EH-MB18 Product numbering	5
4. Electrical Characteristic	6
4.1. Recommend operation conditions	6
4.2. Absolute Maximum Rating	6
4.3. Power consumptions	6
4.4. Input/output Terminal Characteristics	8
4.4.1. Digital Terminals	8
4.4.2. USB	8
4.4.3. Internal CODEC Analogue to Digital Converter	9
4.4.4. Internal CODEC Digital to Analogue Converter	10
5. Pinout and Terminal Description	11
5.1. Pin Configuration	11
6. Physical Interfaces	14
6.1. Power Supply	14
6.2. Reset	14
6.3. PIO	15
6.4. AIO	15
6.5. RF interface	15
6.6. UART	15
6.7. I2C Master	16
6.8. Apple iOS CP reference design	17
6.9. Digital Audio Interfaces	18
6.9.1. PCM	19
6.9.2. Digital Audio Interface (I2S)	19
6.9.3. IEC 60958 Interface (SPDIF)	22
6.10. Microphone input	23
6.11. Analog Output stage	24
6.12. USB	24
7. EH-MB18 Reference Design	26
8. Mechanical and PCB Footprint Characteristics	27
9. RF Layout Guidelines	27
10. Soldering Recommendations	28
11. Certification	28

11.1. BQB	28
11.2. FCC.....	29
11.3. RED	29
11.4. KCC (Korea)	29
11.5. SRRC.....	29
12. Contact Information	29

2. Table of Tables

TABLE 1: RECOMMENDED OPERATING CONDITIONS.....	6
TABLE 2: ABSOLUTE MAXIMUM RATING RECOMMENDED OPERATING CONDITIONS.....	6
TABLE 3: POWER CONSUMPTIONS	7
TABLE 4: DIGITAL TERMINAL	8
TABLE 5: USB TERMINAL.....	9
TABLE 6: ANALOGUE TO DIGITAL CONVERTER.....	9
TABLE 7: DIGITAL TO ANALOGUE CONVERTER.....	10
TABLE 8: PIN TERMINAL DESCRIPTION.....	13
TABLE 9: PIN STATUS ON RESET.....	15
TABLE 10: POSSIBLE UART SETTINGS.....	16
TABLE 11: ALTERNATIVE FUNCTIONS OF THE DIGITAL AUDIO BUS INTERFACE ON THE PCM INTERFACE	18
TABLE 12 : DIGITAL AUDIO INTERFACE SLAVE TIMING.....	20
TABLE 13 : DIGITAL AUDIO INTERFACE MASTER TIMING.....	21
TABLE 14: USB INTERFACE COMPONENT VALUES	25

3. Table of Figures

FIGURE 1: PINOUT OF EH-MB18.....	11
FIGURE 2: POWER SUPPLY PCB DESIGN	14
FIGURE 3: CONNECTION TO HOST DEVICE.....	16
FIGURE 4 : EXAMPLE EEPROM CONNECTION WITH I ² C INTERFACE.....	16
FIGURE 5 : APPLE CO-PROCESSOR 2.0C.....	17
FIGURE 6 : APPLE CO-PROCESSOR 2.0B.....	17
FIGURE 7 : AUDIO INTERFACE	18
FIGURE 8 : DIGITAL AUDIO INTERFACE MODES.....	20
FIGURE 9 : DIGITAL AUDIO INTERFACE SLAVE TIMING.....	21
FIGURE 10: DIGITAL AUDIO INTERFACE MASTER TIMING	21
FIGURE 11: EXAMPLE CIRCUIT FOR SPDIF INTERFACE (CO-AXIAL)	22
FIGURE 12: EXAMPLE CIRCUIT FOR SPDIF INTERFACE (OPTICAL).....	22
FIGURE 13: MICROPHONE BIASING (SINGLE CHANNEL SHOWN).....	23
FIGURE 14: SPEAKER OUTPUT.....	24
FIGURE 15: USB CONNECTIONS	25
FIGURE 16: REFERENCE DESIGN	26
FIGURE 17: RECOMMENDED PCB MOUNTING PATTERN (UNIT: MM, DEVIATION:0.02MM)TOP VIEW.....	27
FIGURE 18: CLEARANCE AREA OF ANTENNA	28

1. Description

The EH-MB18 is an easy to use Bluetooth module, compliant with Bluetooth v4.0. The module provides complete RF platform in a small form factor.

The module enables electronic devices with wireless connectivity, not requiring any RF experience or expertise for integration into the final product. The module being a certified solution optimizes the time to market of the final application.

The module built-in enhanced Kalimba DSP coprocessor with 80MIPS, supports enhanced audio and DSP Applications (t Apt-X, AAC, Apt-XLL, SBC codec).Support GATT,A2DP, AVRCP, HSP, HFP,SPP, iAP and PBAP Profiles communication with smart ready devices.

The module BLE profile communication with smart phones (iOS and Android), must be install the APP. Ehong iOS system APP download address: <https://itunes.apple.com/cn/app/ehong-link/id854886208?mt=8>.

The module has 14 x general purpose IOs, 2x Analogue inputs/outputs (temperature sensor, charger control etc.), 3xs capacitive touch sensors, three fully configurable LED drivers (PWM). The module optional support for 64Mb of external SPI flash 16Mb internal flash memory (64-bit wide, 45ns), support Li-Ion battery charger with Instant-ON.

2. Application

- Home entertainment eco-system
 - ◆ TVs
 - ◆ Smart remote controllers
 - ◆ Wired or wireless sound bars
 - ◆ Wired or wireless speakers and headphones
 - ◆ Bluetooth low energy connectivity to external 3D glasses
- Tablets / PCs / Mobile Connectivity
 - ◆ Wired or wireless headphones for music / gaming / multimedia content
 - ◆ Wired or wireless speakers
 - ◆ Wired or wireless speaker phones
 - ◆ Mono Headsets for voice

3. EH-MB18 Product numbering

EH-MB18(B)

- A. EH ----- Company Name(Ehong)
- B. MB18 ----- Module Name
- C. B ----- U.FL Connector

4. Electrical Characteristic

4.1. Recommend operation conditions

Operating Condition	Min	Typical	Max	Unit
Operating Temperature Range	-40	--	+85	°C
PIO Voltage	+1.7	+3.3	+3.6	V
AIO Voltage	+1.7	+1.8	+1.95	V
LED	+1.1	3.7	+3.6	V
VDD Voltage	+2.7	+3.3	+3.6	V
VCHG(a)	+4.75	+5	+5.75	V
RF frequency	2400	2441	24800	MHz

Table 1: Recommended Operating Conditions

Note:(a) Maximum charging current 200mA

4.2. Absolute Maximum Rating

Rating	Min	Max	Unit
Storage Temperature	-40	+125	°C
PIO Voltage	-0.4	+3.6	V
AIO Voltage	-0.4	+1.95	V
LED	-0.4	+3.6	V
VDD Voltage	-0.4	+3.6	V
VCHG	-0.4	+5.75	V
USB_DP/USB_DN Voltage	-0.4	+3.6	V
Other Terminal Voltages	VSS-0.4	VDD+0.4	V

Table 2: Absolute Maximum Rating Recommended Operating Conditions

4.3. Power consumptions

DUT Role	Connection	Packet Type	Average Current	Unit	
N/A	Deep sleep	With UART host connection	-	55	uA
N/A	Page scan	Page = 1280ms interval Window = 11.25ms	-	219	uA
N/A	Inquiry and page scan	Inquiry = 1280ms interval Page = 1280ms interval Window = 11.25ms	-	378	uA

Master	ACL	Sniff = 500ms, 1 attempt, 0 timeout	DH1	119	uA
Master	ACL	Sniff = 1280ms, 8 attempts, 1 timeout	DH1	109	uA
Master	SCO	Sniff = 100ms, 1 attempt, PCM	HV3	7.6	mA
Master	SCO	Sniff = 100ms, 1 attempt, mono audio codec	HV3	9.8	mA
Master	eSCO	Setting S3, sniff = 100ms, PCM	2EV3	5.8	mA
Master	eSCO	Setting S3, sniff = 100ms, PCM	3EV3	5.4	mA
Master	eSCO	Setting S3, sniff = 100ms, mono audio codec	2EV3	7.9	mA
Master	eSCO	Setting S3, sniff = 100ms, mono audio codec	3EV3	7.5	mA
Slave	ACL	Sniff = 500ms, 1 attempt, 0 timeout	DH1	127	uA
Slave	ACL	Sniff = 1280ms, 8 attempts, 1 timeout	DH1	129	uA
Slave	SCO	Sniff = 100ms, 1 attempt, PCM	HV3	7.8	mA
Slave	SCO	Sniff = 100ms, 1 attempt, mono audio codec	HV3	10	mA
Slave	eSCO	Setting S3, sniff = 100ms, PCM	2EV3	6.2	mA
Slave	eSCO	Setting S3, sniff = 100ms, PCM	3EV3	5.8	mA
Slave	eSCO	Setting S3, sniff = 100ms, mono audio codec	2EV3	8.2	mA
Slave	eSCO	Setting S3, sniff = 100ms, mono audio codec	3EV3	7.9	mA

Table 3: Power consumptions

- Note :** Current consumption values are taken with:
- Firmware ID = 7919
 - RF TX power set to 0dBm
 - No RF retransmissions in case of eSCO
 - Audio gateway transmits silence when SCO/eSCO channel is open
 - LEDs disconnected
 - AFH off

4.4. Input/output Terminal Characteristics

4.4.1. Digital Terminals

Digital Terminals	Min	Type	Max	Unit
Input Voltage				
V _{IL} input logic level low	-0.4	-	0.4	V
V _{IH} input logic level high	0.7 x VDD	-	VDD + 0.4	V
Tr/Tf	-	-	25	ns
Output Voltage				
V _{OL} output logic level low, I _{OL} = 4.0mA	-	-	0.4	V
V _{OH} output logic level high, I _{OH} = -4.0mA	0.75 X VDD	-	-	V
Tr/Tf	-	-	5	ns
Input and Tristate Currents				
Strong pull-up	-150	-40	-10	μA
Strong pull-down	10	40	150	μA
Weak pull-up	-5	-1.0	-0.33	μA
Weak pull-down	0.33	1.0	5.0	μA
C _I Input Capacitance	1.0	-	5.0	pF

Table 4: Digital Terminal

4.4.2. USB

	Min	Type	Max	Unit
VDD_USB for correct USB operation	3.10	3.30	3.60	V
Input Threshold				
V _{IL} input logic level low	-	-	0.30 x VDD_USB	V
V _{IH} input logic level high	0.70 x VDD_USB	-	-	V
Input Leakage Current				
VSS_DIG < V _{IN} < VDD_USB(a)	-1	1	5	μA

C _I input capacitance	2.5	-	10	pF
Output Voltage Levels to Correctly Terminated USB Cable				
V _{OL} output logic level low	0	-	0.2	V
V _{OH} output logic level high	2.80	-	VDD_USB	V

Table 5: USB Terminal

(a) Internal USB pull-up disable

4.4.3. Internal CODEC Analogue to Digital Converter

Analogue to Digital Converter						
Parameter	Conditions	Min	Type	Max	Unit	
Resolution	-	-	-	16	Bits	
Input Sample Rate, F _{sample}	-	8	-	48	kHz	
SNR	f _{in} = 1kHz B/W = 20Hz → F _{samp} le/2 (20kHz max) A-Weighted THD+N < 0.1% 1.6V _{pk-pk} input	F _{sample}				
		8kHz	-	93	-	dB
		16kHz	-	92	-	dB
		32kHz	-	92	-	dB
		44.1kHz	-	92	-	dB
		48kHz	-	92	-	dB
THD+N	f _{in} = 1kHz B/W = 20Hz → F _{samp} le/2 (20kHz max) 1.6V _{pk-pk} input	F _{sample}				
		8kHz	-	0.004	-	%
		48kHz	-	0.008	-	%
Digital gain	Digital gain resolution = 1/32	-24	-	21.5	dB	
Analogue gain	Pre-amplifier setting = 0dB, 9dB, 21dB or 30dB Analogue setting = -3dB to 12dB in 3dB steps	-3	-	42	dB	
Stereo separation (crosstalk)		-	-89	-	dB	

Table 6: Analogue to Digital Converter

4.4.4. Internal CODEC Digital to Analogue Converter

Digital to Analogue Converter							
Parameter	Conditions		Min	Typ	Max	Unit	
Resolution	-		-	-	16	Bits	
Output Sample Rate, F_{sample}	-		8	-	96	kHz	
SNR	$f_{\text{in}} = 1\text{kHz}$ B/W = 20Hz→20kHz A-Weighted THD+N < 0.01% 0dBFS input	F_{sample} Load					
		48kHz 100k Ω	-	96	.	dB	
		48kHz 32 Ω	-	96	.	dB	
		48kHz 16 Ω	-	96	.	dB	
THD+N	$f_{\text{in}} = 1\text{kHz}$ B/W = 20Hz→20kHz Hz 0dBFS input	F_{sample} Load					
		8kHz 100k Ω	-	0.002	-	%	
		8kHz 32 Ω	-	0.002	-	%	
		8kHz 16 Ω	-	0.003	-	%	
		48kHz 100k Ω	-	0.003	-	%	
		48kHz 32 Ω	-	0.003	-	%	
		48kHz 16 Ω	-	0.004	-	%	
Digital Gain	Digital Gain Resolution = 1/32		-24	-	21.5	dB	
Analogue Gain	Analogue Gain Resolution = 3dB		-21	-	0	dB	
Stereo separation (crosstalk)			-	-88	-	dB	

Table 7: Digital to Analogue Converter

5. Pinout and Terminal Description

5.1. Pin Configuration

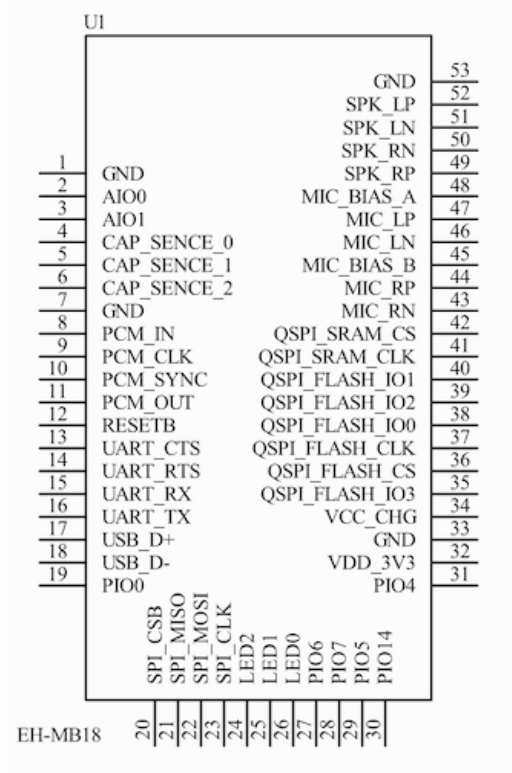

Figure 1: Pinout of EH-MB18

Pin	Symbol	I/O Type	Description
1	GND	Ground	Ground
2	AIO0	Bi-directional	Analogue programmable input/output line
3	AIO1	Bi-directional	Analogue programmable input/output line
4	CAP_SENSE0	Analogue input	Capacitive touch sensor input
5	CAP_SENSE1	Analogue input	Capacitive touch sensor input
6	CAP_SENSE2	Analogue input	Capacitive touch sensor input
7	GND	Ground	Ground
8	PCM_IN	CMOS Input, with weak internal pull-down	Synchronous Data Input
9	PCM_CLK	Bi-directional with weak internal pull-down	Synchronous Data Clock
10	PCM_SYNC	Bi-directional with weak	Synchronous Data Sync

		internal pull-down	
11	PCM_OUT	CMOS output, tri-state, with weak internal pull-down	Synchronous Data Output
12	RESETB	CMOS input with weak internal pull-up	Active LOW RESETB, input debounced so must be low for >5ms to cause a RESETB
13	UART_CTS	Bi-directional with weak pull down	Uart clear to send ,active low
14	UART_RTS	Bi-directional with weak internal pull-up	Uart request to send ,active low
15	UART_RX	CMOS input with weak internal pull-down	Uart data input
16	UART_TX	Bi-directional CMOS output, tri-state, with weak internal pull-up	Uart data output
17	USB_D+	Bi-directional	USB data plus with selectable internal 1.5K pull up resistor
18	USB_D-	Bi-directional	USB data minus
19	PIO0	Bi-directional with programmable strength internal pull-up/down	Programmable input/output line
20	SPI_CSB	Input with weak internal pull-up	Chip select for Synchronous Serial Interface for programming only, active low
21	SPI_MISO	CMOS output, tri-state, with weak internal pull-down	Serial Peripheral Interface output for programming only
22	SPI_MOSI	CMOS input, with weak internal pull-down	Serial Peripheral Interface input for programming only
23	SPI_CLK	Input with weak internal pull-down	Serial Peripheral interface clock for programming only
24	LED2	Open drain output	LED Driver
25	LED1	Open drain output	LED Driver
26	LED0	Open drain output	LED Driver
27	PIO6	Bi-directional with programmable strength internal pull-up/down	Programmable input/output line
28	PIO7	Bi-directional with programmable strength internal pull-up/down	Programmable input/output line or I2C SDA
29	PIO5	Bi-directional with programmable strength internal pull-up/down	Programmable input/output line or I2C SCL

30	PIO14	Bi-directional with programmable strength internal pull-up/down	Programmable input/output line
31	PIO4	Bi-directional with programmable strength internal pull-up/down	Programmable input/output line
32	VDD_3V3	Power Supply	+2.7V- +3.6V power input
33	GND	Ground	Ground
34	VDD_CHG	Charger input	+4.7V--5.7V charge input
35	QSPI_FLASH_IO3	Bi-directional with strong internal pull-down	Serial quad I/O flash data bit 3
36	QSPI_FLASH_CS	Bi-directional with strong internal pull-up	SPI flash chip select
37	QSPI_FLASH_CLK	Bi-directional with strong internal pull-down	SPI flash clock
38	QSPI_FLASH_IO0	Bi-directional with strong internal pull-down	Serial quad I/O flash data bit 0
39	QSPI_FLASH_IO2	Bi-directional with strong internal pull-down	Serial quad I/O flash data bit 2
40	QSPI_FLASH_IO1	Bi-directional with strong internal pull-down	Serial quad I/O flash data bit 1
41	QSPI_SRAM_CLK	Bi-directional with strong internal pull-down	SPI RAM clock
42	QSPI_SRAM_CS	Bi-directional with strong internal pull-up	SPI RAM chip select
43	MIC_RN	Analogue	Microphone input negative, right
44	MIC_RP	Analogue	Microphone input positive, right
45	MIC_BIAS_B	Analogue out	Microphone bias B
46	MIC_LN	Analogue	Microphone input negative, right
47	MIC_LP	Analogue	Microphone input positive, left
48	MIC_BIAS_A	Analogue out	Microphone bias A
49	SPK_RP	Analogue	Speaker output positive, right
50	SPK_RN	Analogue	Speaker output negative, right
51	SPK_LN	Analogue	Speaker output negative, left
52	SPK_LP	Analogue	Speaker output positive, left
53	GND	Ground	Ground

Table 8: PIN Terminal Description

6. Physical Interfaces

6.1. Power Supply

- The module DC3.3V power input.
- Power supply pin connection capacitor to chip and pin as far as possible close
- Capacitor decouples power to the chip
- Capacitor prevents noise coupling back to power plane.

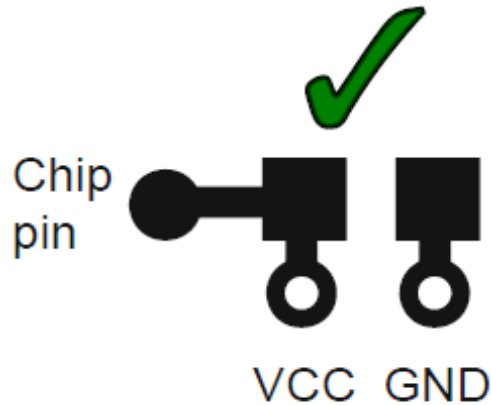

Figure 2: Power Supply PCB Design

6.2. Reset

The module may be reset from several sources: RESETB pin, power-on reset, a UART break character or via software configured watchdog timer.

The RESETB pin is an active low RESETB and is internally filtered using the internal low frequency clock oscillator. A RESETB will be performed between 1.5 and 4.0ms following RESETB being active. It is recommended that RESETB be applied for a period greater than 5ms.

At RESETB the digital I/O pins are set to inputs for bi-directional pins and outputs are tri-state. The pull-down state is shown below.

Pin Name / Group	Pin Status on RESETB
USB_DP	N/a
USB_DN	N/a
UART_RX	Strong PU
UART_TX	Weak PU
UART_RTS	Weak PU
UART_CTS	Weak PD
SPI_MOSI	Weak PD
SPI_CLK	Weak PD
SPI_CSB	Strong PU

SPI_MISO	Weak PD
RESET	Strong PU
PIOs	Weak PD
PCM_IN	Weak PD
PCM_CLK	Weak PD
PCM_SYNC	Weak PD
PCM_OUT	Weak PD
QSPI_SRAM_CS	Strong PU
QSPI_FLASH_CS	Strong PU
QSPI_SRAM_CLK	Strong PD
QSPI_FLASH_CLK	Strong PD

Table 9: Pin Status on Reset

6.3. PIO

EH-MB18 has a total of 13 digital programmable I/O terminals. They are powered from VDD . Their functions depend on firmware running on the device. PIO lines can be configured through software to have either weak or strong pull-ups or pull-downs.

Note:

All PIO lines are configured as inputs with weak pull-downs at reset.

Any of the PIO lines can be configured as interrupt request lines or as wake-up lines from sleep modes.

6.4. AIO

EH-MB18 has 2 analogue I/O terminals. Their functions depend on software. Typically ADC functions can be configured to battery voltage measurement. They can also be used as a digital PIO.

6.5. RF interface

EH-MB18 internet chip antenna and U.fl port choose one of the ways. U.fl port external antenna, impedance is 50 ohm.

6.6. UART

This is a standard UART interface for communicating with other serial devices. The UART interface provides a simple mechanism for communicating with other serial devices using the RS232 protocol.

The UART CTS and RTS signals can be used to implement RS232 hardware flow control where both are active low indicators.

Parameter		Possible Values
Baud Rate	Minimum	1200 baud ($\leq 2\%$ Error)
		9600 baud ($\leq 1\%$ Error)
	Maximum	3M baud ($\leq 1\%$ Error)
Flow Control		RTS/CTS or None
Parity		None, Odd or Even
Number of Stop Bits		1 or 2
Bits per Byte		8

Table 10: Possible UART Settings

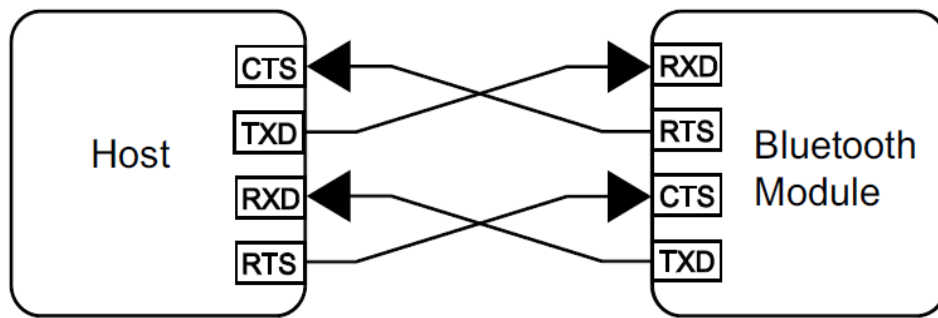

Figure 3: Connection To Host device

6.7. I2C Master

PIO6, PIO7 and PIO8 can be used to form a master I²C interface. The interface is formed using software to drive these lines. It is suited only to relatively slow functions such as driving a LCD, keyboard scanner or EEPROM. In the case, PIO lines need to be pulled up through 2.2K Ω resistors.

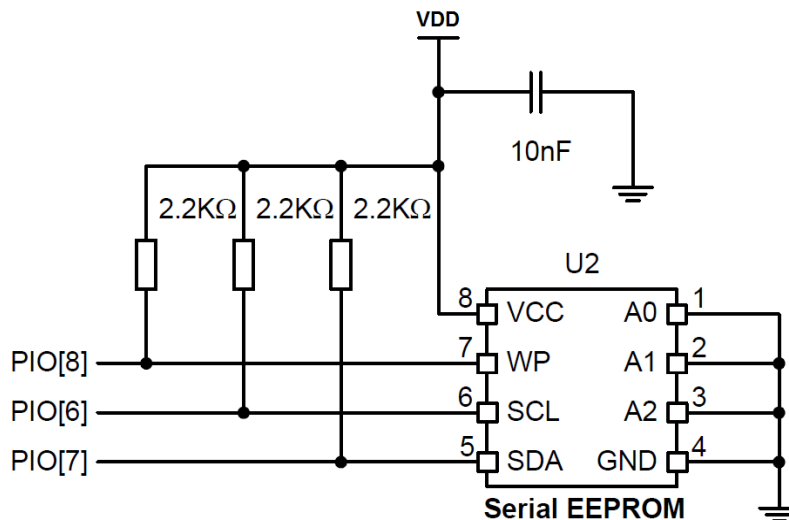

Figure 4 : Example EEPROM Connection with I²C Interface

6.8. Apple iOS CP reference design

The figures below give an indicative overview of what the hardware concept looks like. A specific MFI co-processor layout is available for licensed MFI developers from the MFI program.

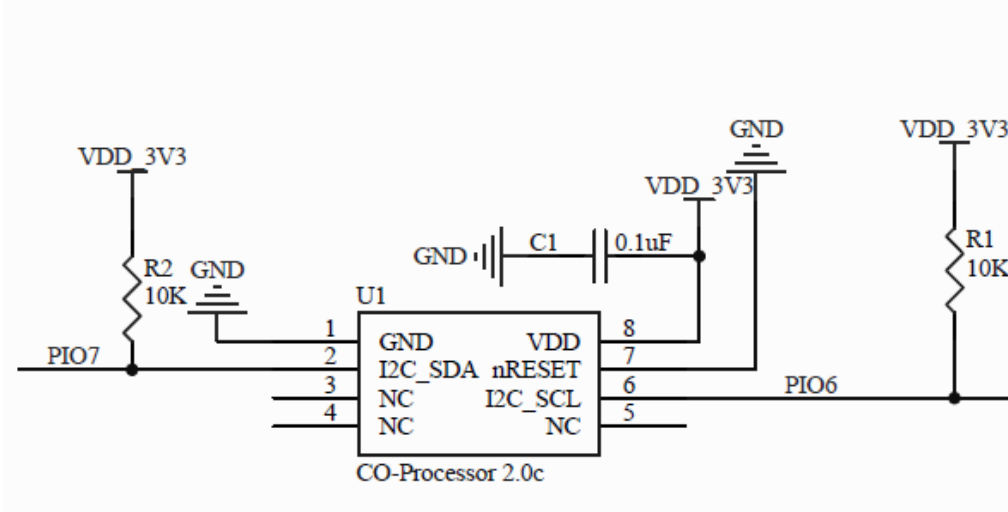

Figure 5 : Apple Co-processor 2.0C

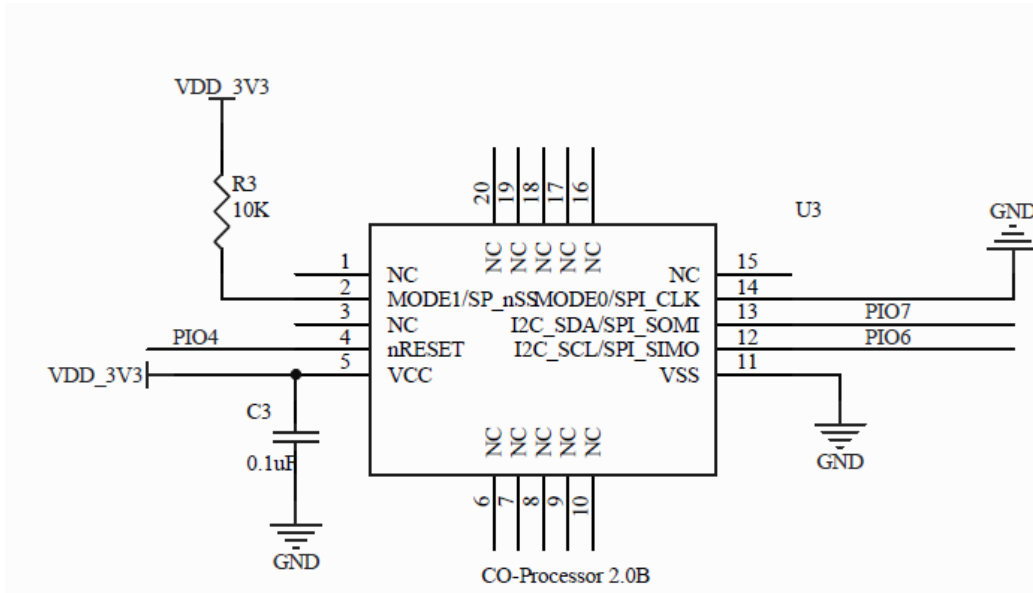

Figure 6 : Apple Co-processor 2.0B

6.9. Digital Audio Interfaces

The audio interface circuit consists of:

- ✧ Stereo/Dual-mono audio codec
- ✧ Dual audio inputs and outputs
- ✧ 6 digital MEMS microphone inputs
- ✧ A configurable PCM, I²S or SPDIF interface

Figure 2 outlines the functional blocks of the interface. The codec supports stereo playback and recording of audio signals at multiple sample rates with a resolution of 16-bit. The ADC and the DAC of the codec each contain 2 independent channels. Any ADC or DAC channel can be run at its own independent sample rate.

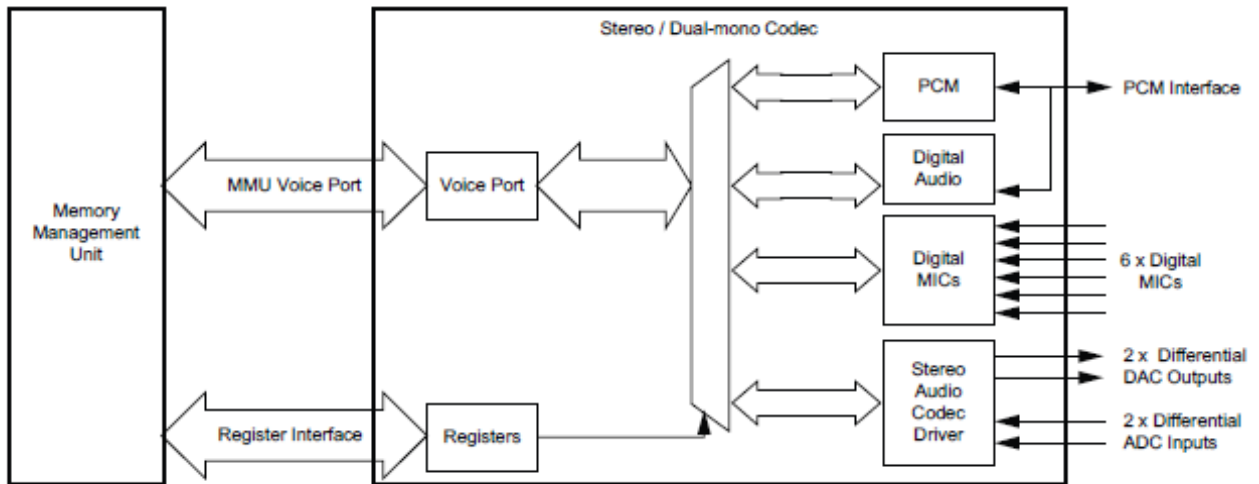

Figure 7 : Audio Interface

The interface for the digital audio bus shares the same pins as the PCM codec interface described in Table 11, which means each of the audio buses are mutually exclusive in their usage. Table 11 lists these alternative functions.

PCM Interface	SPDIF Interface	I ² S Interface
PCM_OUT	SPDIF_OUT	SD_OUT
PCM_IN	SPDIF_IN	SD_IN
PCM_SYNC	-	WS
PCM_CLK	-	SCK

Table 11: Alternative Functions of the Digital Audio Bus Interface on the PCM Interface

The audio input circuitry consists of a dual audio input that can be configured to be either single-ended or fully differential and programmed for either microphone or line input. It has an analogue and digital programmable gain stage for optimization of different microphones. The audio output circuitry consists of a dual differential class A-B output stage.

6.9.1. PCM

The audio pulse code modulation (PCM) interface supports continuous transmission and reception of PCM encoded audio data over Bluetooth.

Hardware on EH-MB18 allows the data to be sent to and received from a SCO connection. Up to three SCO connections can be supported by the PCM interface at any one time.

EH-MB18 can operate as the PCM interface master generating PCM_SYNC and PCM_CLK or as a PCM interface slave accepting externally generated PCM_SYNC and PCM_CLK.

EH-MB18 is compatible with a variety of clock formats, including Long Frame Sync, Short Frame Sync and GCI timing environments.

It supports 13-bit or 16-bit linear, 8-bit u-law or A-law companded sample formats and can receive and transmit on any selection of three of the first four slots following PCM_SYNC.

EH-MB18 interfaces directly to PCM audio devices including the following:

- Qualcomm MSM 3000 series and MSM 5000 series CDMA baseband devices
- OKI MSM7705 four channel A-law and μ -law CODEC
- Motorola MC145481 8-bit A-law and μ -law CODEC
- Motorola MC145483 13-bit linear CODEC
- STW 5093 and 5094 14-bit linear CODECs(8)
- EH-MB18 is also compatible with the Motorola SSI interface

6.9.2. Digital Audio Interface (I2S)

The digital audio interface supports the industry standard formats for I2S, left-justified or right-justified. The interface shares the same pins of the PCM interface as Table 11.

Special firmware is needed if I2S is used. Contact EHong for the special firmware when use I2S as the interface between the module and the host or the codec. The I2S support following formats.

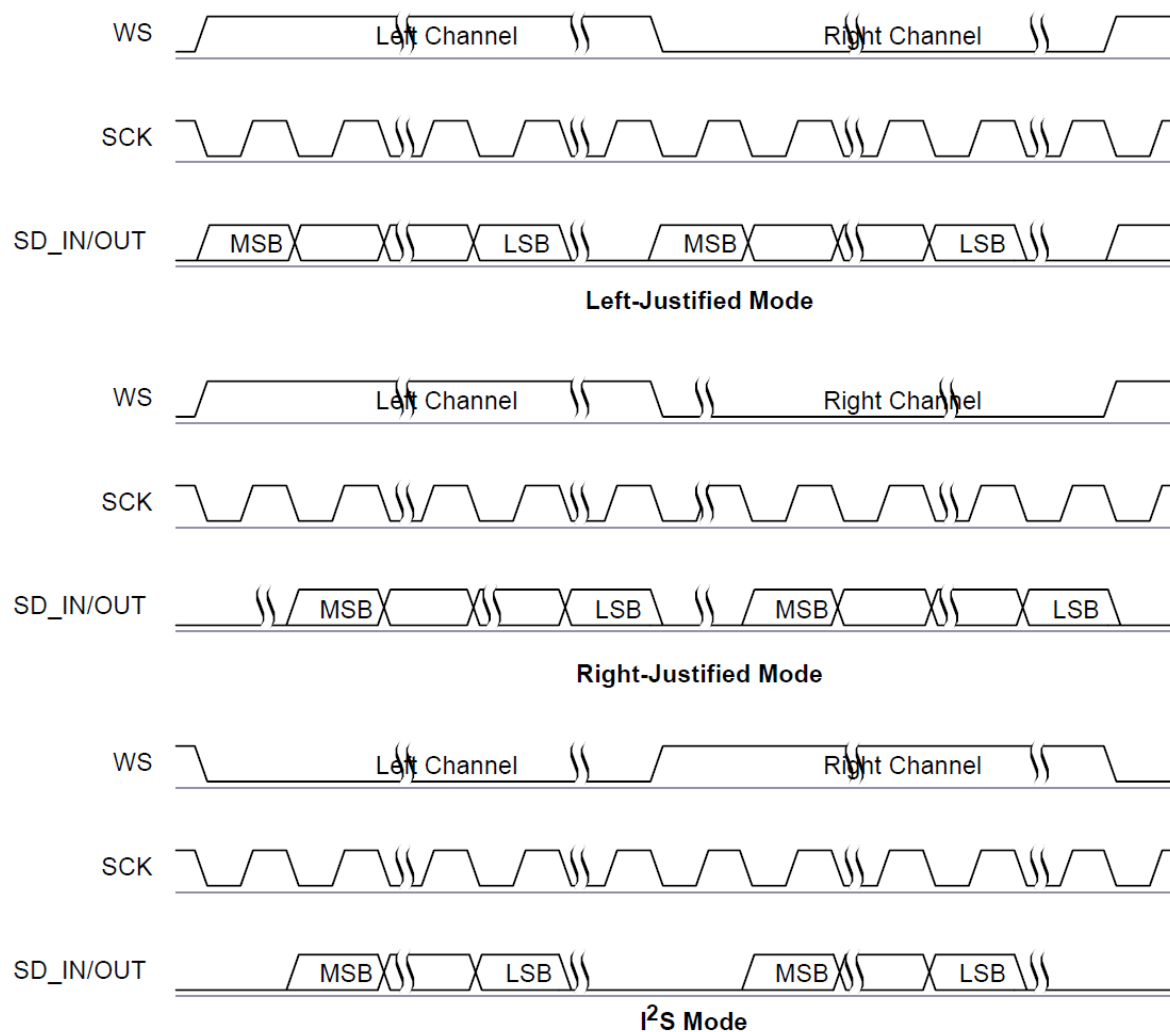

Figure 8 : Digital Audio Interface Modes

Symbol	Parameter	Min	Typical	Max	Unit
-	SCK Frequency	-	-	6.2	MHz
-	WS Frequency	-	-	96	kHz
t_{ch}	SCK high time	80	-	-	ns
t_{cl}	SCK low time	80	-	-	ns
t_{opd}	SCK to SD_OUT delay	-	-	20	ns
t_{ssu}	WS to SCK set up time	20	-	-	ns
t_{sh}	WS to SCK hold time	20	-	-	ns
t_{isu}	SD_IN to SCK set-up time	20	-	-	ns
t_{ih}	SD_IN to SCK hold time	20	-	-	ns

Table 12 : Digital Audio Interface Slave Timing

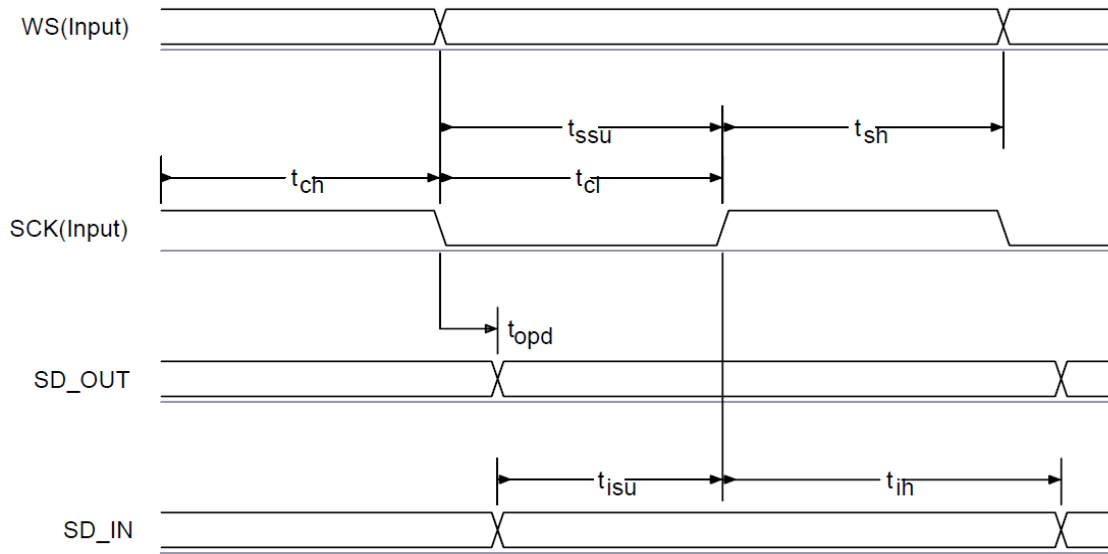

Figure 9 : Digital Audio Interface Slave Timing

Symbol	Parameter	Min	Typical	Max	Unit
-	SCK Frequency	-	-	6.2	MHz
-	WS Frequency	-	-	96	kHz
t_{opd}	SCK to SD_OUT delay	-	-	20	ns
t_{spd}	SCK to WS delay	-	-	20	ns
t_{isu}	SD_IN to SCK set-up time	20	-	-	ns
t_{ih}	SD_IN to SCK hold time	10	-	-	ns

Table 13 : Digital Audio Interface Master Timing

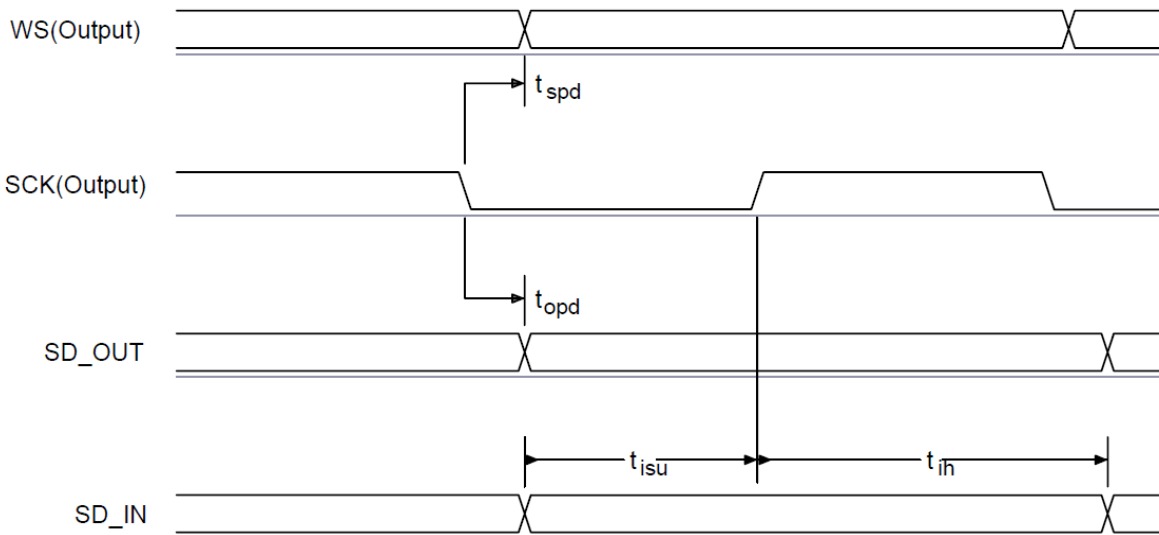

Figure 10 : Digital Audio Interface Master Timing

6.9.3. IEC 60958 Interface (SPDIF)

The IEC 60958 interface is a digital audio interface that uses bi-phase coding to minimise the DC content of the transmitted signal and allows the receiver to decode the clock information from the transmitted signal. The IEC 60958 specification is based on the 2 industry standards:

- AES/EBU
- Sony and Philips interface specification SPDIF

The interface is compatible with IEC 60958-1, IEC 60958-3 and IEC 60958-4.

The SPDIF interface signals are SPDIF_IN and SPDIF_OUT and are shared on the PCM interface pins. The input and output stages of the SPDIF pins can interface to:

- A 75Ω coaxial cable with an RCA connector, see Figure 11.
- An optical link that uses Toslink optical components, see Figure 12.

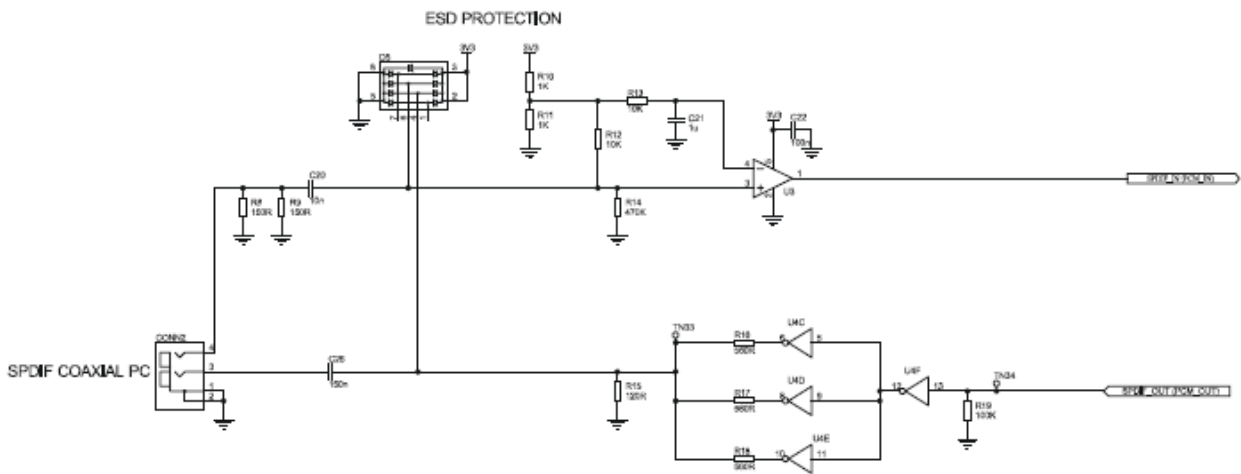

Figure 11: Example Circuit for SPDIF Interface (Co-Axial)

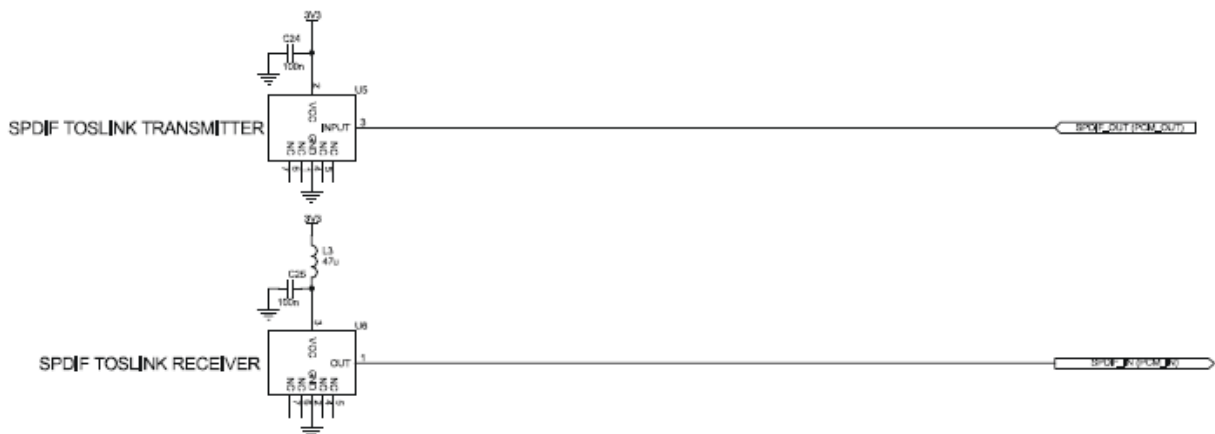

Figure 12: Example Circuit for SPDIF Interface (Optical)

6.10. Microphone input

The module contains 2 independent low-noise microphone bias generators. The microphone bias generators are recommended for biasing electret condenser microphones. Figure 9.6 shows a biasing circuit for microphones with a sensitivity between about - 40 to - 60dB (0dB = 1V/Pa):

- The microphone bias generators derives their power from VBAT or VOUT_3V3 \ and requires no capacitor on its output.
- The microphone bias generators maintains regulation within the limits 70µA to 2.8mA, supporting a 2mA source typically required by 2 electret condenser microphones. If the microphone sits below these limits, then the microphone output must be pre-loaded with a large value resistor to ground.
- Biasing resistors R1 and R2 equal 2.2kΩ.
- The input impedance at MIC_LN, MIC_LP, MIC_RN and MIC_RP is typically 6kΩ.
- C1, C2, C3 and C4 are 100/150nF if bass roll-off is required to limit wind noise on the microphone.
- R1 and R2 set the microphone load impedance and are normally around 2.2kΩ.

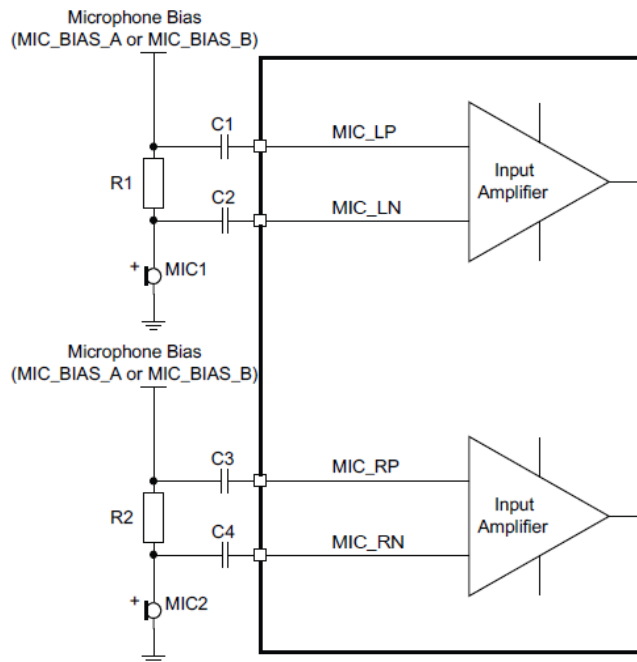

Figure 13: Microphone Biasing (Single Channel Shown)

The microphone bias characteristics include:

- Power supply:
- CSR8670 BGA microphone supply is VBAT (via SMP_VBAT) or VOUT_3V3 (via SMPS_3V3)
- Minimum input voltage = Output voltage + drop-out voltage
- Maximum input voltage is 4.25V
- Drop-out voltage:

- 300mV maximum
- Output voltage:
 - 1.8V or 2.6V
- Tolerance 90% to 110%
- Output current:
 - 70 μ A to 2.8mA
- No load capacitor required

6.11. Analog Output stage

The output stage digital circuitry converts the signal from 16-bit per sample, linear PCM of variable sampling frequency to a 2Mbits/s 5-bit multi-bit bit stream, which is fed into the analogue output circuitry.

The output stage circuit is comprised a DAC with gain setting and class AB amplifier. The output is available as a differential signal between SPKR_A_N and SPKR_L_P for the right channel, as Figure 6 shows, and between SPKL_B_N and SPKL_B_P for the left channel.

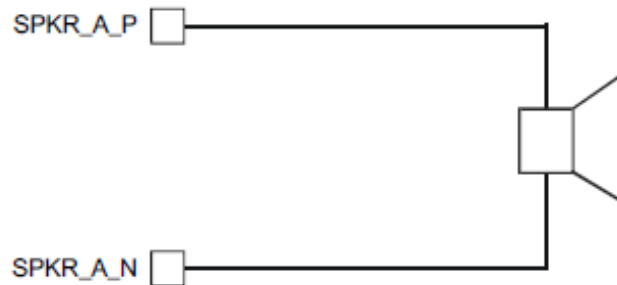

Figure 14: Speaker output

6.12. USB

This is a full speed (12M bits/s) USB interface for communicating with other compatible digital devices. The module acts as a USB peripheral, responding to request from a master host controller, such as a PC.

The USB interface is capable of driving a USB cable directly. No external USB transceiver is required. The device operates as a USB peripheral, responding to requests from a master host controller such as a PC. Both the OHCI and the UHCI standards are supported. The set of USB endpoints implemented can behave as specified in the USB section of the Bluetooth specification v2.1+EDR or alternatively can appear as a set of endpoints appropriate to USB audio devices such as speakers.

The module has an internal USB pull-up resistor. This pulls the USB_DP pin weakly high when module is ready to enumerate. It signals to the USB master that it is a full speed (12Mbit/s) USB device.

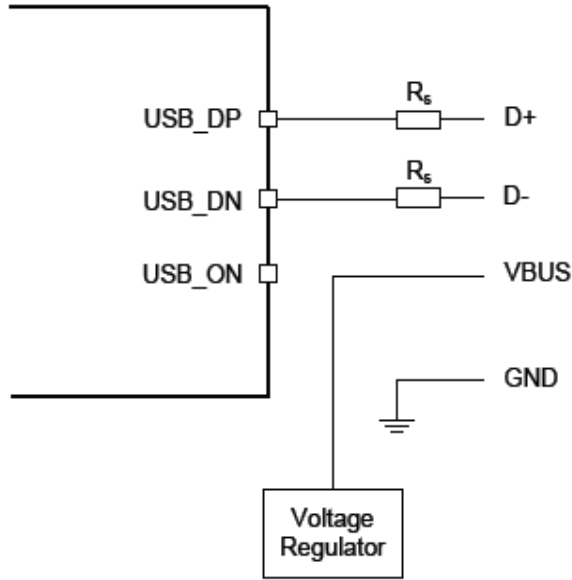

Figure 15: USB Connections

Identifier	Value	Function
R_s	27Ω Nominal	Impedance matching to USB cable

Table 14: USB Interface Component Values

Note:

USB_ON is only used when the firmware need an input to detect if USB is connected and the USB function shall be enabled. In such case it is shared with the module PIO terminals. If detection is not needed (firmware already runs with USB, such as USB DFU or USB CDC), USB_ON is not needed.

7. EH-MB18 Reference Design

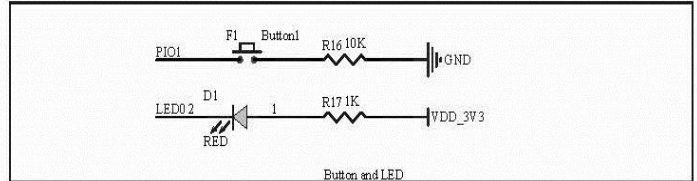
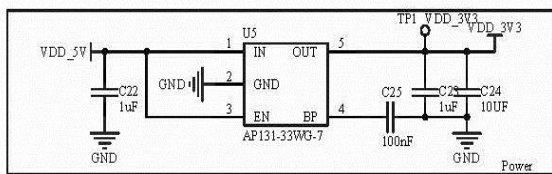
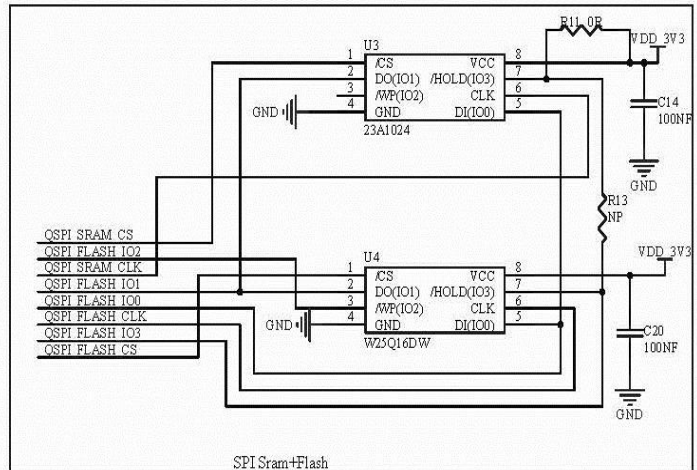
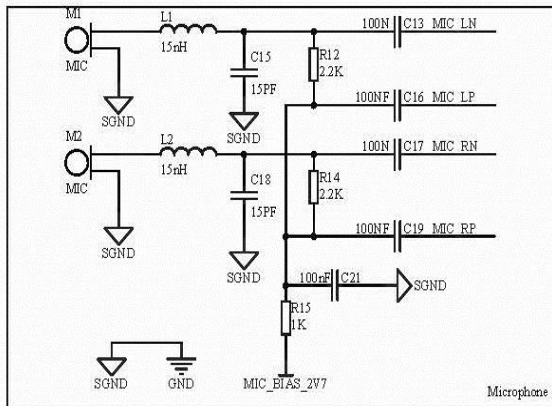
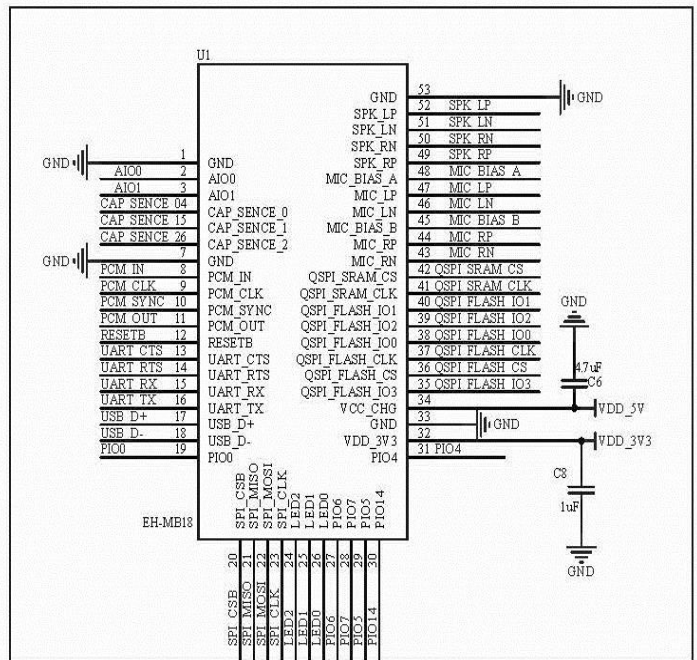
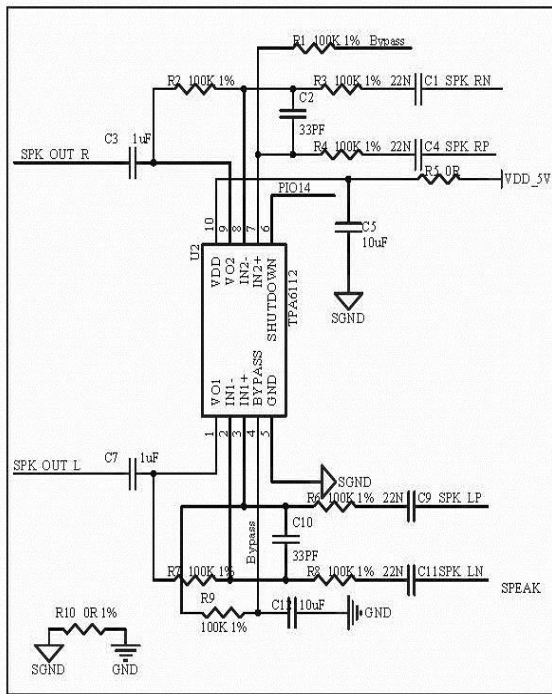

Figure 16: Reference Design

8. Mechanical and PCB Footprint Characteristics

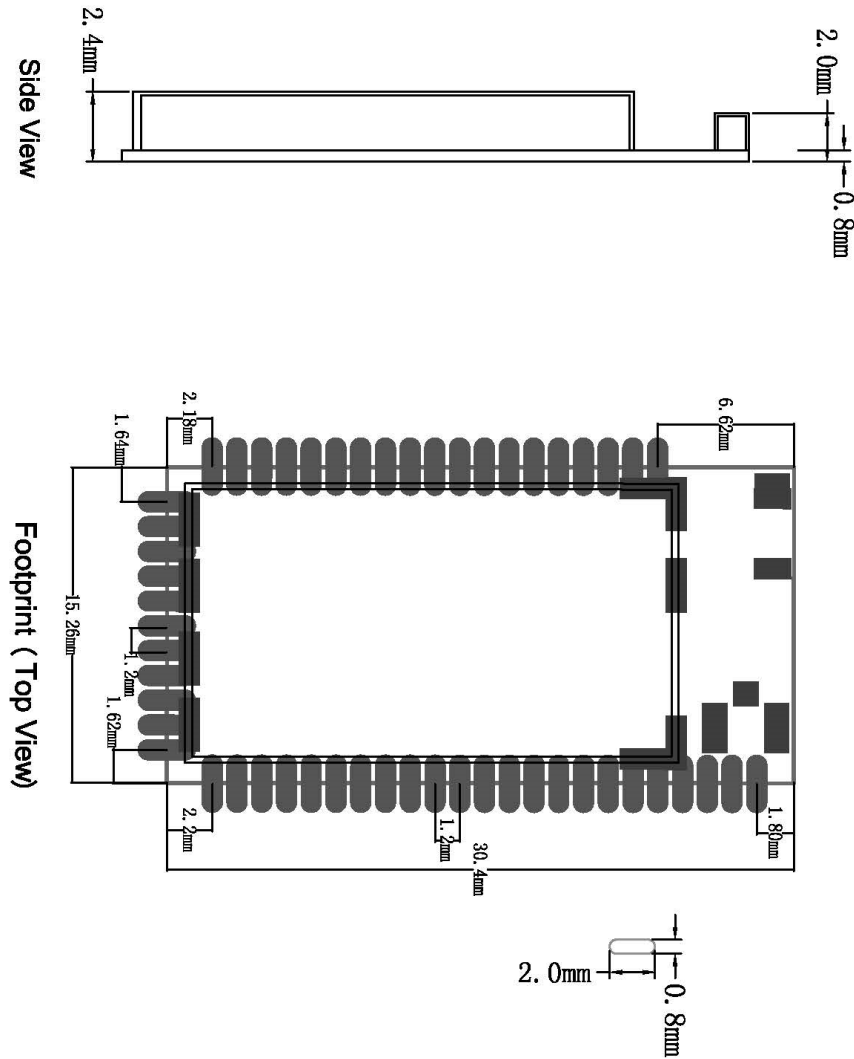

Figure 17: Recommended PCB Mounting Pattern (Unit: mm, Deviation:0.02mm)TOP View

9. RF Layout Guidelines

EH-MB18 RF design to ensure enough clearance area of antenna, area length is 1.6 times of antenna length, area width is 4 times of antenna width, the bigger the better if the space allows. Module antenna clearance area size, as follows.

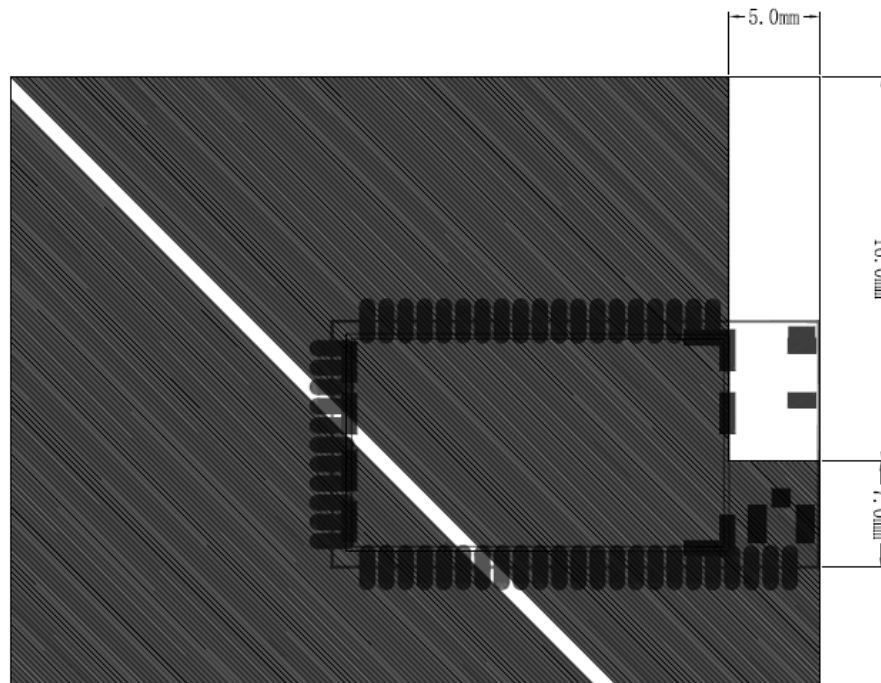

Figure 18: Clearance Area of Antenna

10. Soldering Recommendations

EH-MB18 is compatible with industrial standard reflow profile for Pb-free solders. The reflow profile used is dependent on the thermal mass of the entire populated PCB, heat transfer efficiency of the oven and particular type of solder paste used. Consult the datasheet of particular solder paste for profile configurations.

SMT stencil making requirements

- If Bluetooth module PIN pitch $\geq 0.25\text{mm}$ and other component PIN pitch $\geq 0.25\text{mm}$, so you choose SMT stencil thickness **0.15mm**.
- If Bluetooth module PIN pitch $\geq 0.25\text{mm}$ and other component PIN pitch $\leq 0.25\text{mm}$, so you choose SMT Ladder stencil Bluetooth module thickness **0.15mm** other component thickness **0.13mm**.
- Solder pad open via ratio **Length 1:1.2, width 1:1**.

11. Certification

EH-MB18 is compliant to following specifications.

11.1. BQB

EH-MB18 Bluetooth double module is Bluetooth qualified and listed as a controller subsystem and it is Bluetooth compliant to the following profiles of the core spec V4.2.

11.2. FCC

EH-MB18 complies with Part 15 of the FCC Rules. Operation is subject to the following two conditions:

- (1) this device may not cause harmful interference;
- (2) this device must accept any interference received, including interference that may cause undesired operation.

Contains FCC ID: 2ACCRMB18

11.3. RED

EH-MB18 is in conformity with the essential requirements and other relevant requirements of Radio Equipment Directive (RED) 2014/53/EU. The product is conformity with the following standards and/or normative documents.

- ✧ EMC (immunity only) EN 301 489-17 V.3.2.0 in accordance with EN 301 489-1 V2.2.0
- ✧ Radiated emissions EN 300 328 V2.1.1
- ✧ Safety EN60950-1:2006+A11:2009+A1:2010+A12:2011+A2:2013

11.4. KCC (Korea)

EH-MB18 is KCC certified with following certification number

MSIP-CRI-TGA-EH-MB18

11.5. SRRC

EH-MB18 is in conformity with the essential requirements and other relevant requirements of radio transmission equipment type approval certificate of china.

The CMIIT ID: 2016DP3913

12. Contact Information

Sales: sales@ehonglink.com

Technical support: support@ehonglink.com

Website: <http://www.ehonglink.com>

Tel: +86 21 64769993

Fax: +86 21 64765833

Address: Rm1505,1st, No.833 South Hongmei Rd, MinHang Dis, Shanghai, China